

## INTERACTION OF A SHAPED-CHARGE JET WITH A TARGET POSSESSING AN AXIAL ORIFICE

E. V. Proskuryakov,<sup>1</sup> M. V. Sorokin,<sup>1</sup> and V. M. Fomin<sup>2</sup>

UDC 532.2

*Interaction of a shaped-charge jet with a target possessing an axial orifice is studied experimentally. For an orifice diameter approximately equal to  $0.2D$ , where  $D$  is the shaped-charge diameter, the shaped-charge penetration depth is found to be substantially reduced owing to deviation of the shaped-charge jet axis from the shaped charge axis because of imperfections of the manufacturing technology. A diameter of the target orifice providing unconstrained penetration of the shaped-charge jet is determined.*

**Key words:** *shaped-charge jet, shaped charge, axial channel, charge diameter, axial channel diameter, penetration depth.*

It is known that various devices (instruments, tools, igniters, etc.) possessing axial channels [1] can be placed ahead of the shaped charge (SC) [1]; these devices affect the SC penetration depth. Interaction of a shaped-charge jet (SCJ) with a target possessing an axial orifice (channel) was studied in solving various applied problems.

In an ideal case, the SCJ is expected to penetrate through the target without any constraints if the channel diameter  $d$  is greater than the SCJ diameter. In practice, the SCJ axis deviates from the SC axis of symmetry because the SC production technology is not perfect, and the SCJ elements are scattered in a certain solid angle around the SCJ axis. In addition, the SCJ can interact with the channel walls in different regimes (penetration, rebounding, etc.).

The experiments arranged to study the SCJ interaction with a target are schematically illustrated in Fig. 1. The experiments were performed on model charges with a diameter  $D = 56$  mm, the explosive charge was 40/60 TNT/RDX, and a copper liner with an apex angle equal to  $50^\circ$  was used. The assembly was mounted on a packet of armored plates of medium hardness. The velocity of the leading SCJ front was 7.5 km/sec. The SCJ x-ray photographs taken at different times are shown in Fig. 2. The SCJ diameter did not exceed  $0.1D$ . The length of the target with the orifice was  $1.8D$ . The angle of deviation of the SC axis from the orifice axis due to assembling was smaller than  $0.2^\circ$ .

Experimental results are summarized in Table 1 [ $h$  is the penetration depth in the case the target has an orifice (see Fig. 1),  $\langle h \rangle$  is the mean value of  $h$ ,  $\sigma$  is the root-mean-square deviation of  $h$ , and  $f$  is the distance between the SC and the target with an orifice]. The diameter of the axial channel was  $d = 0, 0.1D, 0.2D, 0.3D, \text{ or } D$ . The case with  $d = 0$  implied that there was no orifice in the target, and the case with  $d = D$  implied that there was no target with an orifice. The distance between the SC and the target was  $f = 1.4D, 3D, \text{ or } 4.6D$ . A series of experiments including 4–5 blasts was performed for each value of  $d$  and  $f$ .

Test No. 14 (with the orifice diameter equal to  $0.3D$  and the distance between the SC and the assembly base equal to  $6.4D$ ) showed that the SCJ experiences no constraints in passing through the orifice. The angle of deviation  $\gamma$  of the SCJ axis from the SC axis is approximately  $1^\circ$ , which is caused by the errors in SC production.

---

<sup>1</sup>Novosibirsk Higher Military Academy (Military Institute), Novosibirsk 630117; saper67@mail.ru.

<sup>2</sup>Khrstianovich Institute of Theoretical and Applied Mechanics, Siberian Division, Russian Academy of Sciences, Novosibirsk 630090. Translated from *Prikladnaya Mekhanika i Tekhnicheskaya Fizika*, Vol. 49, No. 6, pp. 13–16, November–December, 2008. Original article submitted September 24, 2007; revision submitted November 12, 2007.

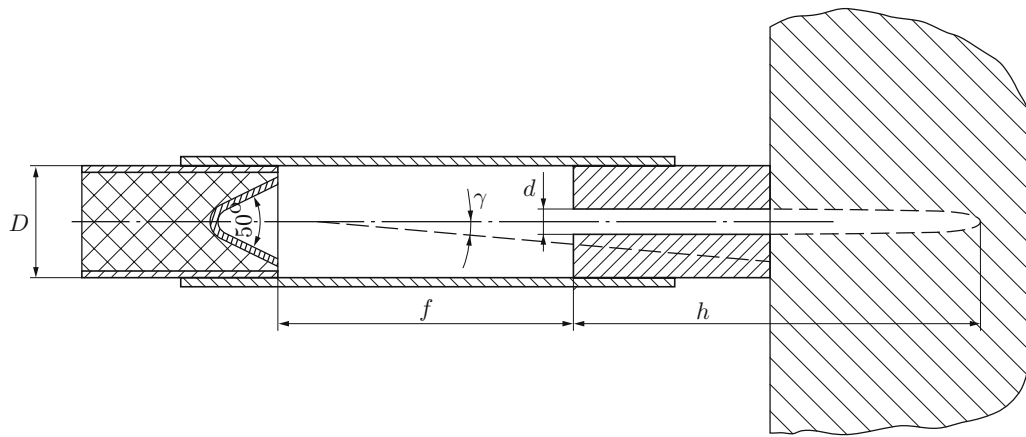

Fig. 1. Experimental arrangement.

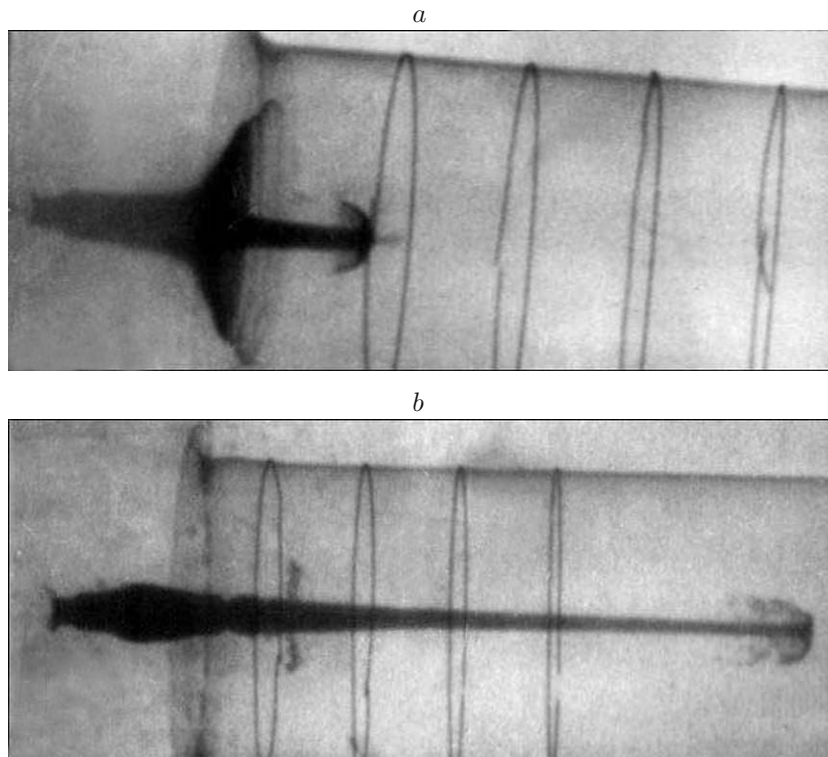

Fig. 2. X-ray photographs of the SCJ taken at  $t = 30$  (a) and  $45 \mu\text{sec}$  (b).

The effect of the wall thickness variation of the SC liner on the angle of deviation  $\gamma$  of the SCJ axis is determined by the parameter  $\Delta/\delta$  ( $\Delta$  is the wall thickness variation of the SC liner and  $\delta$  is the liner thickness [2]). As the charge diameter  $D$  increases, the wall thickness variation  $\Delta$  usually remains unchanged, and the liner thickness  $\delta$  increases in proportion to  $D$ ; as a result, the wall thickness variation  $\Delta$  exerts a smaller effect on the angle of deviation  $\gamma$  of the SCJ axis from the SC axis [2, 3]. The dimensionless orifice diameter necessary for unconstrained SCJ passage can be expected to decrease with increasing diameter  $D$ .

In test Nos. 11 and 13, the presence of the orifice leads to significant reduction of the SC penetration depth: the penetration depth in the case without the orifice is greater than the penetration depth in the case with the

TABLE 1

## Experimental Results

Test number	$f/D$	$d/D$	$h/D$	$\langle h \rangle/D$	$\sigma$	State of the channel after SCJ passage
1	1.4	0	4.05, 3.70, 4.07, 3.89, 3.86	3.91	0.15	No channel in the target
2	1.4	0.1	3.57, 4.91, 5.50, 4.59, 3.69	4.46	0.82	Broken
3	1.4	0.2	6.09, 5.86, 5.86, 5.89, 5.38	5.82	0.26	Partly broken
4	1.4	0.3	6.16, 5.89, 6.77, 6.30, 6.30	6.29	0.32	Not broken
5	1.4	1.0	6.59, 6.48, 6.29, 6.34, 6.34	6.41	0.12	No target with a channel
6	3.0	0	4.80, 4.69, 4.50, 4.55, 4.55	4.62	0.12	No channel in the target
7	3.0	0.1	3.96, 4.89, 3.57, 3.75, 4.89	4.21	0.63	Broken
8	3.0	0.2	6.34, 5.38, 5.85, 5.38, 4.38	5.47	0.73	Partly broken
9	3.0	0.3	6.02, 6.50, 6.82, 5.89	6.31	0.43	Not broken
10	3.0	1.0	6.34, 5.54, 6.34, 7.26, 6.34	6.36	0.61	No target with a channel
11	4.6	0	4.55, 3.75, 4.55, 5.48, 4.55	4.59	0.61	No channel in the target
12	4.6	0.1	4.95, 3.63, 4.79, 4.63, 4.96	4.59	0.56	Broken
13	4.6	0.2	3.04, 3.93, 3.18, 4.39, 4.00	3.77	0.68	Broken
14	4.6	0.3	6.20, 6.07, 6.14, 3.92, 5.93	5.65	0.97	Partly broken
15	4.6	1.0	6.23, 4.90, 6.46, 6.46, 6.73	6.15	0.73	No target with a channel

orifice approximately by  $0.8D$ . Such a decrease in the SC penetration depth can be hardly explained within the framework of the hydrodynamic model of penetration [4]. It is assumed that angular scattering of the SCJ leads to its interaction with the orifice surface, which involves SCJ rebounding and its curving in an oblique shock wave [5]. As a result, the penetration depth of the curved SCJ becomes considerably smaller.

Thus, the SCJ interaction with a target possessing an axial orifice is studied experimentally. A diameter of the target orifice providing unconstrained penetration of the shaped-charge jet is determined. For an orifice diameter approximately equal to 0.2 of the charge diameter, the SCJ penetration depth is found to be substantially reduced owing to SCJ curving as a result of its rebounding from the orifice surface.

## REFERENCES

1. M. M. Rastopshin, "Methods of fighting against tanks equipped with dynamic protection," *Tekh. Vooruzh.*, No. 10, 14–20 (1977).
2. V. A. Tarasov, V. D. Baskakov, and M. A. Dubovskoi, "Influence of technological heredity on the penetration effect of shaped charges," *Oboron. Tekh.*, No. 4, 54–59 (1995).
3. L. P. Orlenko (ed.), *Physics of Explosion* [in Russian], Vol. 2, Fizmatlit, Moscow (2004), pp. 299–309.
4. M. A. Lavrent'ev and B. V. Shabat, *Hydrodynamics Problems and Their Mathematical Models* [in Russian], Nauka, Moscow (1973), pp. 260–270.
5. V. M. Fomin, A. I. Gulidov, G. A. Sapozhnikov, et al., *High-Velocity Interaction of Bodies* [in Russian], Izd. Sib. Div. Ross. Akad. Nauk, Novosibirsk (1999), pp. 387–390.